

BASIC SIZE	0-3	>3-6	>6-10	>10-18	>18-30	>30-50	>50-80	>80-120	>120-180	>180-250
DIMS TOLERANCE	±0.14	±0.18	±0.22	±0.27	±0.33	±0.39	±0.46	±0.54	±0.63	±0.72

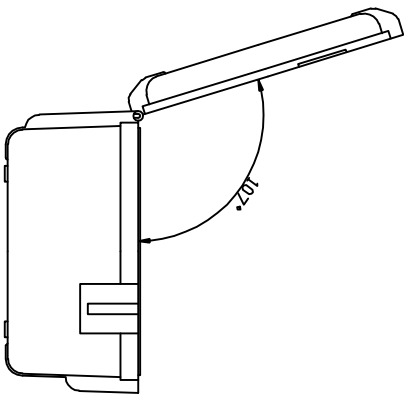
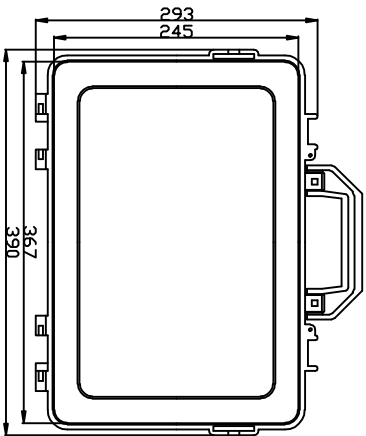
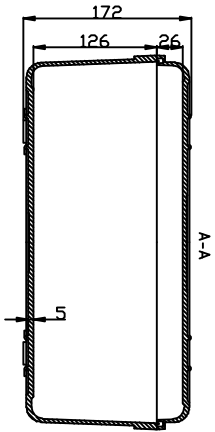
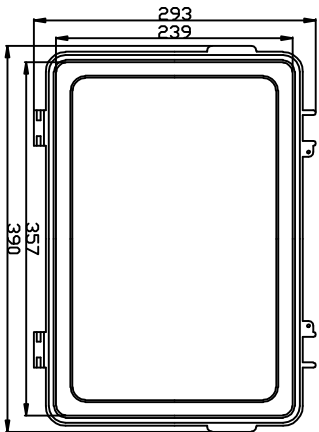
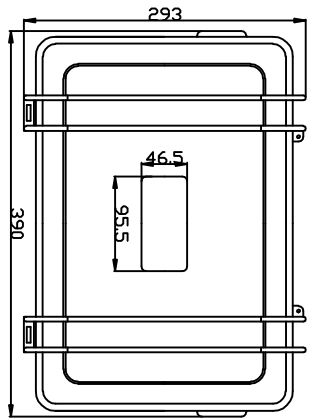
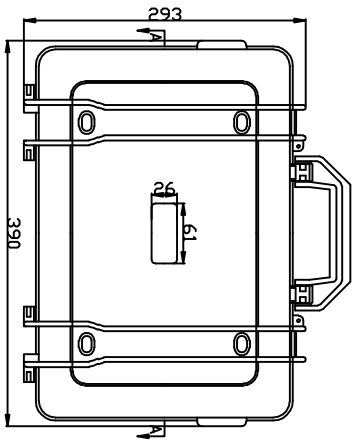

THE MACHINING TOLERANCES		NAME	DATE
UNSPECIFIED TOLERANCES FOLLOW GB/1804-1992 IT13	DRAWN		
FDAM	CHECKED		
THE ANGLE TOLERANCES	ENG APPR		
±3mm			
THE ANGLE TOLERANCES	QTY	1	
±1°	SCALE	1:1	
FIRST ANGLE PROJECTION	UNIT	mm	
	DD NOT SCALE DRAWING		
	SHEET 1		DF 1

**DRX.EVEREST**  
WWW.EVERESTCASE.COM

TITLE **EVEREST CASE**

MATERIAL **ABS**

/PART NO **EP013-2**